

7. Masonry

7.1 Scope

This chapter sets forth requirements for the Systematic Rehabilitation of concrete- or clay-unit masonry lateral-force-resisting elements within a building. The requirements of this chapter shall apply to existing masonry components of a building system, rehabilitated masonry components of a building system, and new masonry components that are added to an existing building system.

Sections 7.2 and 7.3 specify data collection procedures for obtaining material properties and performing condition assessments. Sections 7.4 and 7.5 provide modeling procedures, component strengths, acceptance criteria, and rehabilitation measures for masonry walls and masonry infills. Section 7.6 specifies requirements for anchorage to masonry walls. Section 7.7 specifies requirements for masonry foundation elements.

C7.1 Scope

The provisions of this chapter should be applied to solid or hollow clay-unit masonry, solid or hollow concrete-unit masonry, and hollow clay tile. Stone or glass block masonry is not covered in this chapter.

Portions of masonry buildings that are not subject to systematic rehabilitation provisions include parapets, cladding, and partition walls.

If the Simplified Rehabilitation Method of Chapter 10 is followed, unreinforced masonry buildings with flexible floor diaphragms may be evaluated using the procedures given in *FEMA 310*.

Techniques for repair of earthquake-damaged masonry components are not included in this standard. The design professional is referred to *FEMA 306*, *FEMA 307*, and *FEMA 308* for information on evaluation and repair of masonry wall components.

7.2 Historical Information

Available construction documents and as-built information shall be obtained as specified in Section 2.2. Use of material properties based on historical information as default values shall be as

specified in Section 7.3.2.10. Other values of material properties shall be permitted if rationally justified, based on available historical information for a particular type of masonry construction, prevailing codes, and assessment of existing conditions.

C7.2 Historical Information

Construction of existing masonry buildings in the United States dates back to the 1500s in the southeastern and southwestern regions, to the 1770s in the central and eastern regions, and to the 1850s in the western half of the nation. The stock of existing masonry buildings in the United States is composed largely of structures constructed in the last 150 years. Since the types of units, mortars, and construction methods changed during this time, knowing the age of a masonry building may be useful in identifying the characteristics of its construction. Although structural properties cannot be inferred solely from age, some background on typical materials and methods for a given period can help to improve engineering judgment and provide some direction in the assessment of an existing building. The design professional should be aware that values given in some existing documents are working stress values rather than expected or lower-bound strengths used in this standard.

As indicated in Chapter 1, great care should be exercised in selecting the appropriate rehabilitation approaches and techniques for application to historic buildings to preserve their unique characteristics.

7.3 Material Properties and Condition Assessment

7.3.1 General

Mechanical properties for masonry materials and components shall be based on available construction documents and as-built conditions for the particular structure. Where such information fails to provide adequate information to quantify material properties or document the condition of the structure, such information shall be supplemented by materials tests and assessments of existing conditions as required in Section 2.2.6.

Material properties of existing masonry components shall be determined in accordance with Section 7.3.2. A condition assessment shall be conducted in accordance with Section 7.3.3. The extent of materials testing and condition assessment performed shall be used to determine the knowledge factor as specified in Section 7.3.4.

Use of default material properties shall be permitted in accordance with Section 7.3.2.10.

Procedures for defining masonry structural systems and assessing masonry condition shall be conducted in accordance with the provisions stated in Section 7.3.3.

7.3.2 Properties of In-Place Materials

7.3.2.1 General

The following component and connection material properties shall be obtained for the as-built structure in accordance with Sections 7.3.2.1 through 7.3.2.10:

1. Masonry compressive strength.
2. Masonry tensile strength.
3. Masonry shear strength.
4. Masonry elastic modulus.
5. Masonry shear modulus.
6. Strength and modulus of elasticity of reinforcing steel.

When materials testing is required by Section 2.2.6, test methods to quantify material properties shall comply with Sections 7.3.2.2 through 7.3.2.8. The minimum number of tests shall comply with the requirements of Section 7.3.2.9.

Expected material properties shall be based on mean values from test data. Lower bound material properties shall be based on mean values from test data minus one standard deviation.

The condition of existing masonry shall be classified as good, fair, or poor as defined in this standard, or based

on other approved procedures that consider the nature and extent of damage or deterioration present.

C7.3.2.1 General

The design professional is referred to *FEMA 306*, *FEMA 307*, and *FEMA 308* for additional information regarding the condition of masonry. The classification of the condition of masonry requires consideration of the type of component, the anticipated mode of inelastic behavior, and the nature and extent of damage or deterioration. These documents also contain extensive information regarding the effects of damage on strength, stiffness, and displacement limits for masonry components. Included are damage classification guides with visual representations of typical earthquake-related damage of masonry components, which may be useful in classifying the condition of masonry for this standard. The severity of damage described in *FEMA 306*, *FEMA 307*, and *FEMA 308* is categorized as Insignificant, Slight, Moderate, Heavy, and Extreme. Masonry in good condition shall have severity of damage not exceeding Insignificant or Slight, as defined by *FEMA 306*. Masonry in fair condition shall have severity of damage not exceeding Moderate. Masonry with Heavy or Extreme damage shall be classified as Poor.

7.3.2.2 Nominal or Specified Properties

Nominal material properties, or properties specified in construction documents, shall be taken as lower-bound material properties. Corresponding expected material properties shall be calculated by multiplying lower-bound values by a factor as specified in Table 7-2 to translate from lower-bound to expected values.

7.3.2.3 Masonry Compressive Strength

Expected masonry compressive strength, f_{me} , shall be measured using one of the following three methods.

1. Test prisms shall be extracted from an existing wall and tested in accordance with Section 1.4.B.3 of *ACI 530.1/ASCE 6/TMS 602 Specifications for Masonry Structures*.
2. Prisms shall be fabricated from actual extracted masonry units, and a surrogate mortar designed on the basis of a chemical analysis of actual mortar samples. The test prisms shall be tested in

accordance with Section 1.4.B.3 of *ACI 530.1/ASCE 6/TMS 602*.

3. For solid unreinforced masonry, the strength of the masonry can be estimated using a flatjack test in accordance with *ASTM C1196-92*.

For each of the three methods enumerated in this section, the expected compressive strength shall be based on the net mortared area.

If the masonry unit strength and the mortar type are known, f_{me} values shall be taken from Tables 1 and 2 of *ACI 530.1/ASCE 6/TMS 602* for clay or concrete masonry constructed after 1960. The f_{me} value shall be obtained by multiplying the table values by a factor as specified in Table 7-2 to translate lower-bound masonry compressive strength to expected strength.

C7.3.2.3 Masonry Compressive Strength

The three test methods are further described in Section C7.3.2.1 of *FEMA 274*. As an alternative to the test methods given in this section of the standard, the expected masonry compressive strength may be deduced from a nominal value prescribed in *ACI 530.1/ASCE 6/TMS 602*.

Default values of compressive strength are set at very low stresses to reflect an absolute lower bound. Masonry in poor condition is given a strength equal to one-third of that for masonry in good condition, to reflect the influence of mortar deterioration and unit cracking on compressive strength.

7.3.2.4 Masonry Elastic Modulus in Compression

Expected values of elastic modulus for masonry in compression, E_{me} , shall be measured using one of the following two methods:

1. Test prisms shall be extracted from an existing wall and tested in compression. Stresses and

deformations shall be measured to determine modulus values.

2. For solid unreinforced masonry, the modulus can be measured using a flatjack test in accordance with *ASTM C1197-92*.

C7.3.2.4 Masonry Elastic Modulus in Compression

Both methods measure vertical strain between two gage points to infer strain, and thus elastic modulus. They are further described in *FEMA 274* Section C7.3.2.2. The coefficient of 550 for default values in Table 7-1 is set lower than values given in *IBC (2000)* to compensate for larger values of expected strength.

7.3.2.5 Masonry Flexural Tensile Strength

Expected flexural tensile strength, f_{te} , for out-of-plane bending shall be measured using one of the following three methods:

1. Test samples shall be extracted from an existing wall and subjected to minor-axis bending using the bond-wrench method of *ASTM C1072-99*.
2. Test samples shall be tested in situ using the bond-wrench method.
3. Sample wall panels shall be extracted and subjected to minor-axis bending in accordance with *ASTM E518-00*.

Flexural tensile strength for unreinforced masonry (URM) walls subjected to in-plane lateral forces shall be assumed to be equal to that for out-of-plane bending, unless testing is done to define the expected tensile strength for in-plane bending.

C7.3.2.5 Masonry Flexural Tensile Strength

The flexural tensile strength of older brick masonry walls constructed with lime mortars may often be neglected. The tensile strength of newer concrete- and clay-unit masonry walls can result in appreciable flexural strengths.

The three test methods for out-of-plane bending are further described in Section C7.3.2.3 of *FEMA 274*. For in-plane bending, flexural stress gradients across the section width are much lower than for out-of-plane bending. Thus, data from tests described in this section will be very conservative and should be used only in lieu of data on in-plane tensile strength. Default values for flexural tensile strength are set low even for masonry in good condition because of its dependence on the unit-mortar bonding, which can be highly variable due to the variability of the condition of the mortar.

7.3.2.6 Masonry Shear Strength

For URM components, expected masonry shear strength, v_{me} , shall be measured using an approved in-place shear test. Expected shear strength shall be determined in accordance with Equation (7-1):

$$v_{me} = \frac{0.75 \left(0.75 v_{te} + \frac{P_{CE}}{A_n} \right)}{1.5} \quad (7-1)$$

where:

- P_{CE} = Expected gravity compressive force applied to a wall or pier component considering load combinations given in Equations (3-18) and (3-19)
- A_n = Area of net mortared/grouted section of a wall or pier
- v_{te} = Average bed-joint shear strength, v_{to} , given in Equation (7-2)

Values for the mortar shear strength, v_{te} , shall not exceed 100 psi for the determination of v_{me} in Equation (7-1). The 0.75 factor on v_{te} shall not be applied for single wythe masonry walls.

Individual bed joint shear strength test values, v_{to} , shall be determined in accordance with Equation (7-2):

$$v_{to} = \frac{V_{test}}{A_b} - P_{D+L} \quad (7-2)$$

where:

- V_{test} = Test load at first movement of a masonry unit
- A_b = Sum of net mortared area of bed joints above and below the test unit
- P_{D+L} = Stress due to gravity loads at the test location

The in-place shear test shall not be used to estimate shear strength of reinforced masonry components. The expected shear strength of reinforced masonry components shall be determined in accordance with Section 7.4.4.2.

C7.3.2.6 Masonry Shear Strength

The available standard for masonry shear strength test is *UBC 21-6*. Section C7.3.2.4 of *FEMA 274* further describes this test and also an alternate procedure. Comparison of default values with values that may be obtained from Equation (7-1) shows that if in-place shear tests are done, a significant increase in strength over default values is possible.

7.3.2.7 Masonry Shear Modulus

The expected shear modulus of masonry (unreinforced or reinforced), G_{me} , shall be permitted to be taken as 0.4 times the elastic modulus in compression.

C7.3.2.7 Masonry Shear Modulus

Shear stiffness of post-cracked masonry should be taken as a fraction of the initial uncracked masonry shear stiffness value. The design professional is referred to *FEMA 274* Section C7.3.2.5 for additional information regarding masonry shear modulus.

7.3.2.8 Strength and Modulus of Reinforcing Steel

The expected yield strength of reinforcing bars, f_{ye} , shall be based on mill test data, or tension tests of actual reinforcing bars taken from the subject building. Tension tests shall be performed in accordance with *ASTM A615/A615M-00*.

The modulus of elasticity of steel reinforcement, E_{se} , shall be assumed to be 29,000,000 psi.

7.3.2.9 Minimum Number of Tests

Materials testing is not required if material properties are available from original construction documents that include material test records or material test reports.

7.3.2.9.1 Usual Testing

The minimum number of tests to determine masonry and reinforcing steel material properties for usual data collection shall be based on the following criteria:

1. If the specified design strength of the masonry is known, and the masonry is in good or fair condition, at least one test shall be performed on samples of each different masonry strength used in the construction of the building, with a minimum of three tests performed for the entire building. If the masonry is in poor condition, additional tests shall be performed to determine the extent of the reduced material properties.
2. If the specified design strength of the masonry is not known, at least one test shall be performed on each type of component, with a minimum of six tests performed on the entire building.
3. If the specified design strength of the reinforcing steel is known, use of nominal or specified material properties shall be permitted without additional testing.
4. If the specified design strength of the reinforcing steel is not known, at least two strength coupons of reinforcing steel shall be removed from a building for testing.

7.3.2.9.2 Comprehensive Testing

The minimum number of tests necessary to quantify properties by in-place testing for comprehensive data collection shall be based on the following criteria:

1. For masonry in good or fair condition as defined in this standard, a minimum of three tests shall be performed for each masonry type, and for each three floors of construction or 3,000 square feet of wall

surface, if original construction records are available that specify material properties; six tests shall be performed if original construction records are not available. At least two tests shall be performed for each wall or line of wall elements providing a common resistance to lateral forces. A minimum of eight tests shall be performed for each building.

2. For masonry in poor condition as defined in this standard, additional tests shall be done to estimate material strengths in regions where properties differ, or nondestructive condition assessment tests in accordance with Section 7.3.3.2 shall be used to quantify variations in material strengths.

Samples for tests shall be taken at locations representative of the material conditions throughout the entire building, taking into account variations in workmanship at different story levels, variations in weathering of the exterior surfaces, and variations in the condition of the interior surfaces due to deterioration caused by leaks and condensation of water and/or the deleterious effects of other substances contained within the building.

An increased sample size shall be permitted to improve the confidence level. The relation between sample size and confidence shall be as defined in *ASTM E139-00*.

If the coefficient of variation in test measurements exceeds 25%, the number of tests performed shall be doubled.

If mean values from in situ material tests are less than the default values prescribed in Section 7.3.2.10, the number of tests performed shall be doubled.

C7.3.2.9 Minimum Number of Tests

The number and location of material tests should be selected to provide sufficient information to adequately define the existing condition of materials in the building. Test locations should be identified in those masonry components that are determined to be critical to the primary path of lateral-force resistance.

7.3.2.10 Default Properties

Use of default material properties to determine component strengths shall be permitted with the linear analysis procedures in Chapter 3.

Default lower-bound values for masonry compressive strength, elastic modulus in compression, flexural tensile strength, and masonry shear strength shall be based on Table 7-1. Default expected strength values for masonry compressive strength, elastic modulus in compression, flexural tensile strength, and masonry shear strength shall be determined by multiplying

lower-bound values by an appropriate factor taken from Table 7-2.

Default lower-bound and expected strength yield stress values for reinforcing bars shall be determined in accordance with Section 6.3.2.5.

Table 7-1 Default Lower-Bound Masonry Properties

Property	Masonry Condition ¹		
	Good	Fair	Poor
Compressive Strength (f'_m)	900 psi	600 psi	300 psi
Elastic Modulus in Compression	$550f'_m$	$550f'_m$	$550f'_m$
Flexural Tensile Strength ²	20 psi	10 psi	0
Shear Strength³			
Masonry with a running bond lay-up	27 psi	20 psi	13 psi
Fully grouted masonry with a lay-up other than running bond	27 psi	20 psi	13 psi
Partially grouted or ungrouted masonry with a lay-up other than running bond	11 psi	8 psi	5 psi

1. Masonry condition shall be classified as good, fair, or poor as defined in this standard.

Table 7-2 Factors to Translate Lower-Bound Masonry Properties to Expected Strength Masonry Properties¹

Property	Factor
Compressive Strength (f_{me})	1.3
Elastic Modulus in Compression ²	–
Flexural Tensile Strength	1.3
Shear Strength	1.3

- See Chapter 6 for properties of reinforcing steel.
- The expected elastic modulus in compression shall be taken as $550f_{me}$, where f_{me} is the expected masonry compressive strength.

7.3.3 Condition Assessment

A condition assessment of the existing building and site conditions shall be performed as specified in Sections 7.3.3.1 through 7.3.3.3.

A condition assessment shall include the following:

1. The physical condition of primary and secondary components shall be examined and the presence of any degradation shall be noted.
2. The presence and configuration of components and their connections, and the continuity of load paths between components, elements, and systems shall be verified or established.
3. Other conditions, including the presence and attachment of veneer, neighboring party walls and buildings, presence of nonstructural components, prior remodeling, and limitations for rehabilitation that may influence building performance, shall be identified and documented.

The condition of the masonry shall be classified as good, fair, or poor as defined in this standard, based on the results of visual examination conducted in accordance with Section 7.3.3.1.

C7.3.3 Condition Assessment

Buildings are often constructed with veneer as an architectural finish, which may make the wall appear thicker than the actual structural thickness. In many areas of the country, the veneer wythe is separated from the structural wall by an air space to provide ventilation and moisture control. This is called cavity wall construction. In this case, the veneer may be anchored, but does not add any strength to the assembly.

In areas of the southwest United States and along the California coast (as well as other regions), the veneer is placed directly against the building wall. It will be in a running bond pattern without a header course. Other patterns are also seen. If the veneer is not anchored, or has a layer of building paper between it and the inner wythe, it cannot be considered as part of the structural wall.

Veneer on modern buildings may be adhered or anchored. In either case, the veneer is a weight to be considered, but does not contribute to a wall's strength. In all cases, the veneer must be anchored to prevent its detaching during an earthquake. Requirements for veneer are specified in Chapter 11.

Face brick bonded to the inner wythes with a regular pattern of header courses is not veneer. In this case, the outer wythes are part of the structural wall, and can be used in evaluating the height-to-thickness ratio of the wall.

See Section C7.3.2.1 regarding the use of *FEMA 306*, *FEMA 307*, and *FEMA 308* for additional information in classifying the condition of masonry.

7.3.3.1 Visual Condition Assessment

The size and location of all masonry shear and bearing walls shall be determined by visual examination. The orientation and placement of the walls shall be noted. Overall dimensions of masonry components shall be measured or determined from plans, including wall heights, lengths, and thicknesses. Locations and sizes of window and door openings shall be measured or determined from plans. The distribution of gravity loads to bearing walls shall be estimated.

Walls shall be classified as reinforced or unreinforced, composite or noncomposite, and grouted, partially grouted, or ungrouted. For reinforced masonry (RM) construction, the size and spacing of horizontal and

vertical reinforcement shall be estimated. For multi-wythe construction, the number of wythes shall be noted, as well as the distance between wythes, and the placement of inter-wythe ties. The condition and attachment of veneer wythes shall be noted. For grouted construction, the quality of grout placement shall be assessed. For partially grouted walls, the locations of grout placement shall be identified.

The type and condition of the mortar and mortar joints shall be determined. Mortar shall be examined for weathering, erosion, and hardness, and to identify the condition of any repointing, including cracks, internal voids, weak components, and/or deteriorated or eroded mortar. Horizontal cracks in bed joints, vertical cracks in head joints and masonry units, and diagonal cracks near openings shall be noted.

Vertical components that are not straight shall be identified. Bulging or undulations in walls shall be observed, as well as separation of exterior wythes, out-of-plumb walls, and leaning parapets or chimneys.

Connections between masonry walls and floors or roofs shall be examined to identify details and condition. If construction drawings are available, a minimum of three connections shall be inspected for each connection type. If no deviations from the drawings are found, the sample shall be considered representative. If drawings are unavailable, or if deviations are noted between the drawings and constructed work, then a random sample of connections shall be inspected until a representative pattern of connections is identified.

7.3.3.2 Comprehensive Condition Assessment

The following nondestructive tests shall be permitted to quantify and confirm the uniformity of construction quality and the presence and degree of deterioration for comprehensive data collection:

1. Ultrasonic or mechanical pulse velocity to detect variations in the density and modulus of masonry materials and to detect the presence of cracks and discontinuities.

2. Impact echo test to confirm whether reinforced walls are grouted.
3. Radiography to confirm location of reinforcing steel.

The location and number of nondestructive tests shall be determined in accordance with the requirements of Section 7.3.2.9.2.

C7.3.3.2 Comprehensive Condition Assessment

Nondestructive tests may be used to supplement the visual observations required by Section 7.3.3.1.

C7.3.3.2.1 Ultrasonic Pulse Velocity

Measurement of the velocity of ultrasonic pulses through a wall can detect variations in the density and modulus of masonry materials as well as the presence of cracks and discontinuities. Transmission times for pulses traveling through a wall (direct method) or between two points on the same side of a wall (indirect method) are measured and used to infer wave velocity.

Test equipment with wave frequencies in the range of 50 kHz has been shown to be appropriate for masonry walls. Use of equipment with higher frequency waves is not recommended because the short wave length and high attenuation are not consistent with typical dimensions of masonry units. Test locations should be sufficiently close to identify zones with different properties. Contour maps of direct transmission wave velocities can be constructed to assess the overall homogeneity of a wall elevation. For indirect test data, vertical or horizontal distance can be plotted versus travel time to identify changes in wave velocity (slope of the curve). Abrupt changes in slope will identify locations of cracks or flaws.

Ultrasonic methods are not applicable for masonry of poor quality or low modulus, or with many flaws and cracks. The method is sensitive to surface condition, the coupling material used between the transducer or receiver and the brick, and the pressure applied to the transducer.

The use of ultrasonic pulse velocity methods with masonry walls has been researched extensively by Calvi (1988); Epperson and Abrams (1989); Kingsley et al. (1987). A standard for the use of ultrasonic methods for masonry is currently under development in Europe with RILEM Committee 76LUM.

C7.3.3.2.2 Mechanical Pulse Velocity

The mechanical pulse velocity test consists of impacting a wall with a hammer blow and measuring the travel time of a sonic wave across a specified gage distance. An impact hammer is equipped with a load cell or accelerometer to detect the time of impact. A distant accelerometer is fixed to a wall to detect the arrival time of the pulse. Wave velocity is determined by dividing the gage length by the travel time. The form and duration of the generated wave can be varied by changing the material on the hammer cap.

The generated pulse has a lower frequency and higher energy content than an ultrasonic pulse, resulting in longer travel distances and less sensitivity to small variations in masonry properties and minor cracking. The mechanical pulse method should be used in lieu of the ultrasonic pulse method when overall mean properties of a large portion of masonry are of interest.

The use of mechanical pulse velocity measurements for masonry condition assessments has been confirmed through research by Epperson and Abrams (1989) and Kingsley et al. (1987). Although no standard exists for mechanical pulse velocity tests with masonry, a standard for concrete materials (*ASTM C597-97*) does exist.

C7.3.3.2.3 Impact Echo

The impact-echo technique can be useful for nondestructive determination of the location of void areas within grouted reinforced walls - Sansalone and Carino (1988). Commercial devices are available or systems can be assembled using available electronic components. Since this technique cannot distinguish between a shrinkage crack at the grout-unit interface and a complete void in the grout, drilling of small holes in the bed joint or examination using an optical borescope should be performed to verify the exact condition.

C7.3.3.2.4 Radiography

A number of commercial radiographic (x-ray) devices exist that can be used to identify the location of reinforcing steel in masonry walls. They are also useful for locating bed-joint reinforcing steel, masonry ties and anchors, and conduits and pipes. The better devices can locate a No. 6 bar at depths up to approximately six inches; however, this means that for a 12-inch-thick concrete masonry wall, a bar located off-center cannot be found when access is limited to only one side of the wall. These devices are not able to locate or determine the length of reinforcing bar splices in walls in most cases. They work best for identifying the location of single isolated bars and become less useful when the congestion of reinforcing bars increases.

7.3.3.3 Supplemental Tests

Supplemental tests shall be permitted to enhance the level of confidence in masonry material properties, or the assessment of masonry condition for justifying the use of a higher knowledge factor, as specified in Section 7.3.4.

C7.3.3.3 Supplemental Tests

Ancillary tests are recommended, but not required, to enhance the level of confidence in masonry material properties, or to assess condition. Possible supplemental tests are described below.

C7.3.3.3.1 Surface Hardness

The surface hardness of exterior-wythe masonry can be evaluated using the Schmidt rebound hammer. Research has shown that the technique is sensitive to differences in masonry strength, but cannot by itself be used to determine absolute strength. A Type N hammer (5000 lb.) is recommended for normal-strength masonry, while a Type L hammer (1600 lb.) is recommended for lower-strength masonry. Impacts at the same test location should be continued until consistent readings are obtained, because surface roughness can affect initial readings.

The method is limited to tests of only the surface wythe. Tuckpointing may influence readings and the method is not sensitive to cracks.

Measurement of surface hardness for masonry walls has been studied by Noland et al. (1987).

C7.3.3.3.2 Vertical Compressive Stress

In situ vertical compressive stress resisted by the masonry can be measured using a thin hydraulic flat jack that is inserted into a removed mortar bed joint. Pressure in the flat jack is increased until distortions in the brickwork are reduced to the pre-cut condition. Existing vertical compressive stress is inferred from the jack hydraulic pressure, using correction factors for the shape and stiffness of the flat jack.

The method is useful for measurement of gravity load distribution, flexural stresses in out-of-plane walls, and stresses in masonry veneer walls that are compressed by a surrounding concrete frame. The test is limited to only the face wythe of masonry.

Not less than three tests should be done for each section of the building for which it is desired to measure in situ vertical stress. The number and location of tests should be determined based on the building configuration and the likelihood of overstress conditions.

C7.3.3.3.3 Diagonal Compression Test

A square panel of masonry is subjected to a compressive force applied at two opposite corners along a diagonal until the panel cracks. Shear strength is inferred from the measured diagonal compressive force based on a theoretical distribution of shear and normal stress for a homogeneous and elastic continuum. Using the same theory, shear modulus is inferred from measured diagonal compressive stress and strain.

Extrapolation of the test data to actual masonry walls is difficult because the ratio of shear to normal stress is fixed at a constant ratio of 1.0 for the test specimens. Also, the distribution of shear and normal stresses across a bed joint may not be as uniform for a test specimen as for an actual wall. Lastly, any redistribution of stresses after the first cracking will not be represented with the theoretical stress distributions. Thus, the test data cannot be useful to predict nonlinear behavior.

If the size of the masonry units relative to the panel dimension is large, masonry properties will be not continuous, but discrete. Test panels should be a minimum of four feet square. The high cost and disruption of extracting a number of panels this size may be impractical. The standard test method specified in *ASTM E519-81* may be used.

C7.3.3.3.4 Large-Scale Load Tests

[Large-scale destructive tests may be done on portions of a masonry component or element to (1) increase the confidence level on overall structural properties, (2) obtain performance data on archaic building materials and construction materials, (3) quantify effects of complex edge and boundary conditions around openings and two-way spanning, and (4) verify or calibrate analytical models. Large-scale load tests do not necessarily have to be run to the ultimate limit state. They may have value for simply demonstrating structural integrity up to some specific Performance Level.

Out-of-plane strength and behavior of masonry walls can be determined with air-bag tests. Behavior of test panels incorporating connections and edge details can be determined from such a test, in addition to flexural and arching properties of a solid or perforated wall. Strength and deformation capacity under in-plane lateral forces can be determined by loading an individual portion of wall that is cut free of the surrounding masonry. Loading actuators are reacted against adjacent and stronger portions of masonry. Such testing is particularly useful when the wall is composed of different materials that cannot be evaluated by testing an individual unit of an individual wythe.

Visual and nondestructive surveys should be used to identify locations for test samples.

Standards for laboratory test methods are published by ASTM. Procedures for removal and transportation of masonry samples are given in *NBS 62*.

Large-scale tests are expensive and limited to a single or few samples. They may result in considerable local damage and may require substantial reconstruction near the sample location. Test data must be extrapolated to the remainder of the system, based on a low confidence level.

7.3.4 Knowledge Factor

A knowledge factor for computation of masonry component capacities and permissible deformations shall be selected in accordance with Section 2.2.6.4.

7.4 Engineering Properties of Masonry Walls

The procedures set forth in this section for determination of stiffness, strength, and deformation of masonry walls shall be applied to building systems comprising any combination of existing masonry walls, masonry walls enhanced for seismic rehabilitation, and new walls added to an existing building for seismic rehabilitation.

Actions in a structure shall be classified as being either deformation-controlled or force-controlled as defined in Section 2.4.4.3. Design strengths for deformation-controlled and force-controlled actions shall be calculated in accordance with this section.

Strengths used for deformation-controlled actions are denoted Q_{CE} and shall be taken as equal to expected strengths obtained experimentally, calculated using accepted mechanics principles, or based on default values listed in Section 7.3.2.10. Expected strength is defined as the mean maximum resistance expected over the range of deformations to which the component is likely to be subjected. When calculations are used to define expected strength, expected material properties shall be used. Unless otherwise specified in this standard, use of procedures specified in *IBC* (2000) to calculate design strengths shall be permitted except that the strength reduction factor, ϕ , shall be taken equal to unity.

Force-controlled actions shall be as defined in Section 2.4.4. Strengths used in design for force-controlled actions are denoted Q_{CL} and shall be taken as equal to lower bound strengths obtained experimentally, calculated using established mechanics principles, or based on default values listed in Section 7.3.2.10. Lower bound strength is defined as the mean minus one standard deviation of resistance over the range of deformations and loading cycles to which the component is subjected. When calculations are used to define lower bound strengths, lower bound material properties shall be used. Unless otherwise specified in this standard, use of procedures specified in *IBC* (2000)

to calculate design strengths shall be permitted except that the strength reduction factor, ϕ , shall be taken equal to unity. Where alternative definitions of design strength are used, they shall be justified by experimental evidence.

Where design actions are determined using the nonlinear procedures of Chapter 3, component force-deformation response shall be represented by nonlinear force-deformation relations. Force-deformation relations shall be based on experimental evidence or the generalized force-deformation relation shown in Figure 7-1, with parameters c , d , and e as defined in Tables 7-4 and 7-7.

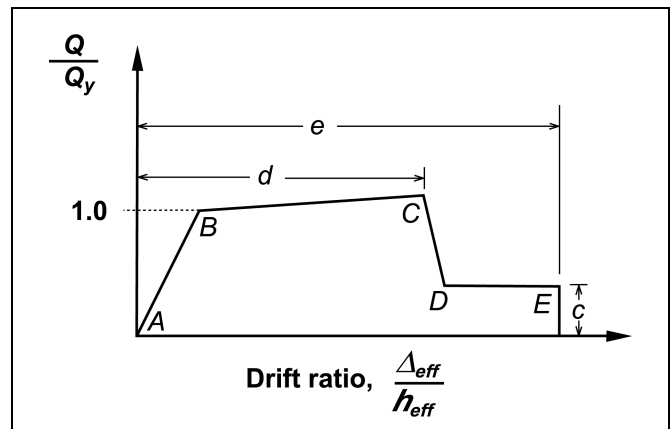

Figure 7-1 Generalized Force-Deformation Relation for Masonry Elements or Components

C7.4 Engineering Properties of Masonry Walls

Expected yield strength of reinforcing steel, as specified in this standard, includes consideration of material overstrength and strain hardening.

Component drift ratios are the ratio of differential displacement, Δ_{eff} , between each end of the component over the effective height, h_{eff} , of the component. Depending on the geometry of the wall or pier configuration, the elevations at which these parameters are determined may vary within the same wall element, as shown in Figure C7-1.

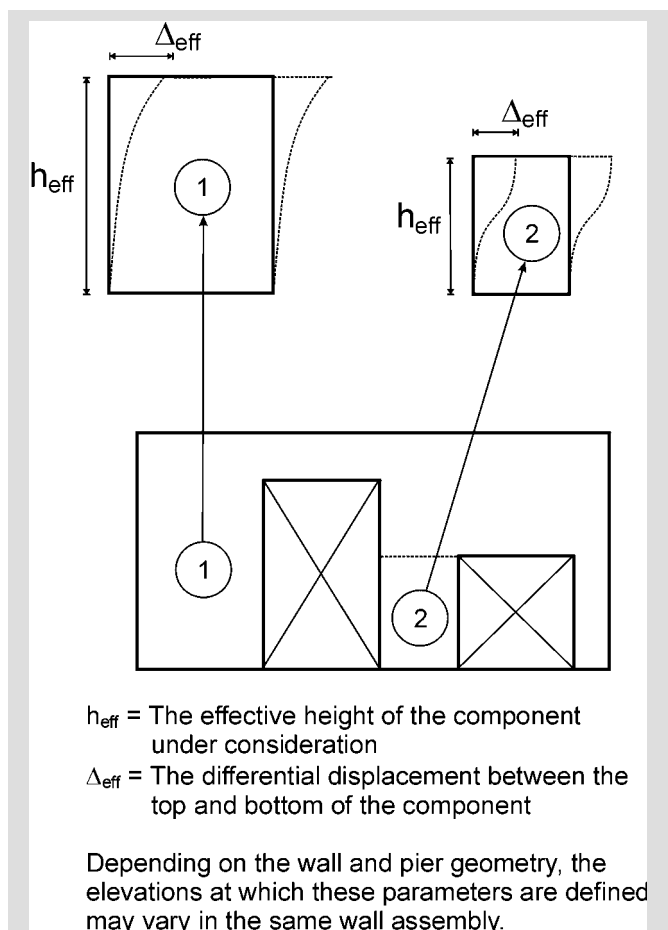

Figure C7-1 Effective Height and Differential Displacement of Wall Components

7.4.1 Types of Masonry Walls

Masonry walls shall be categorized as unreinforced or reinforced; ungrouted, partially grouted, or fully grouted; and composite or noncomposite. Masonry walls shall be capable of resisting forces applied parallel to their plane and normal to their plane, as described in Sections 7.4.2 through 7.4.5.

C7.4.1 Types of Masonry Walls

Any of these categories of masonry elements can be used in combination with existing, rehabilitated, or new lateral-force-resisting elements of other materials such as steel, concrete, or timber.

7.4.1.1 Existing Masonry Walls

Existing masonry walls shall include all structural walls of a building system that are in place prior to seismic rehabilitation.

Existing masonry walls shall be assumed to behave in the same manner as new masonry walls, provided that the masonry is in fair or good condition as defined in this standard.

7.4.1.2 New Masonry Walls

New masonry walls shall include all new wall elements added to an existing lateral force-resisting system. Design of new walls shall follow the requirements set forth in an approved building code.

C7.4.1.2 New Masonry Walls

Codes for new buildings include the *International Building Code (IBC)*, *National Building Code (NBC)*, *Standard Building Code (SBC)*, and the *Uniform Building Code (UBC)*. Guidelines for seismic design of new buildings are found in *FEMA 302*.

7.4.1.3 Enhanced Masonry Walls

Enhanced masonry walls shall include existing walls that are rehabilitated by an approved method.

C7.4.1.3 Enhanced Masonry Walls

Methods of enhancing masonry walls are intended to improve performance of masonry walls subjected to both in-plane and out-of-plane lateral forces.

Possible rehabilitation methods are described in Sections C7.4.1.3.1 through C7.4.1.3.10.

C7.4.1.3.1 Infilled Openings

An infilled opening may be considered to act compositely with the surrounding masonry if new and old masonry units are interlaced at the boundary with full toothing, or attached with anchorage that provides compatible shear strength at the interface of new and old units.

Stiffness assumptions, strength criteria, and acceptable deformations for masonry walls with infilled openings should be the same as given for non-rehabilitated solid masonry walls; differences in elastic moduli and strengths for the new and old masonry walls should be considered for the composite section.

C7.4.1.3.2 Enlarged Openings

Openings in URM shear walls may be enlarged by removing portions of masonry above or below windows or doors.

Openings are enlarged to increase the height-to-length aspect ratio of piers so that the limit state may be altered from shear to flexure. This method is only applicable to URM walls.

Stiffness assumptions, strength criteria, and acceptable deformations for URM walls with enlarged openings shall be reassessed to reflect the final condition of the wall.

C7.4.1.3.3 Shotcrete

An existing masonry wall with an application of shotcrete may be considered to behave as a composite section if anchorage is provided at the shotcrete-masonry interface to transfer the shear forces calculated in accordance with Chapter 3. Stresses in the masonry and shotcrete should be determined considering the difference in elastic moduli for each material, or the existing masonry wall should be neglected and the new shotcrete layer should be designed to resist all of the force.

Stiffness assumptions, strength criteria, and acceptable deformations for masonry components with shotcrete should be the same as that for new reinforced concrete components. Variations in boundary conditions should be considered.

C7.4.1.3.4 Coatings for Unreinforced Masonry Walls

A coated masonry wall may be considered a composite section as long as anchorage is provided at the interface between the coating and the masonry wall to transfer shear forces. Stresses in the masonry and coating should be determined considering the difference in elastic moduli for each material. If stresses exceed expected strengths of the coating material, then the coating should be considered ineffective.

Stiffness assumptions, strength criteria, and acceptable deformations for coated masonry walls should be the same as that for existing URM walls.

C7.4.1.3.5 Reinforced Cores for Unreinforced Masonry Walls

A reinforced-cored masonry wall should be considered to behave as a reinforced masonry wall, provided that the bond between the new reinforcement and the grout and between the grout and the cored surface are capable of transferring seismic forces computed in accordance with Chapter 3. Vertical reinforcement should be anchored at the base of the wall to resist the full tensile strength of the wall.

Grout in new reinforced cores should consist of cementitious materials whose hardened properties are compatible with those of the surrounding masonry.

Adequate shear strength must exist, or should be provided, so that the strength of the new vertical reinforcement can be developed.

Stiffness assumptions, strength criteria, and acceptable deformations for URM walls with reinforced cores should be the same as that for existing reinforced walls.

C7.4.1.3.6 Prestressed Cores for Unreinforced Masonry Walls

A prestressed-cored masonry wall with unbonded tendons should be considered to behave as a URM wall with increased vertical compressive stress.

Losses in prestressing force due to creep and shrinkage of the masonry should be accounted for in analyses conducted in accordance with Chapter 3.

Stiffness assumptions, strength criteria, and acceptable deformations for URM walls with unbonded prestressing tendons should be the same as for existing unreinforced masonry walls subjected to vertical compressive stress.

C7.4.1.3.7 Grout Injections

Grout used for filling voids and cracks should have strength, modulus, and thermal properties compatible with the existing masonry.

Inspections should be conducted in accordance with Chapter 2 during the grouting process to ensure that voids are completely filled with grout.

Stiffness assumptions, strength criteria, and acceptable deformations for masonry walls with grout injections should be the same as that for existing unreinforced or reinforced walls.

C7.4.1.3.8 Repointing

Bond strength of new mortar should be equal to or greater than that of the original mortar. Compressive strength of new mortar should be equal to or less than that of the original mortar.

Stiffness assumptions, strength criteria, and acceptable deformations for repointed masonry walls should be the same as that for existing masonry walls.

C7.4.1.3.9 Braced Masonry Walls

Masonry walls with height-to-thickness ratios in excess of those permitted by Table 7-5, or out-of-plane bending stresses in excess of those permitted by Section 7.4.3.2, may be braced with external structural elements. Adequate strength should be provided in the bracing element and connections to resist the transfer of forces from the masonry wall to the bracing element. Out-of-plane deflections of braced walls resulting from the transfer of vertical floor or roof loadings should be considered.

Stiffness assumptions, strength criteria, and acceptable deformations for braced masonry walls should be the same as that for existing masonry walls. The reduced span of the masonry wall should be considered.

C7.4.1.3.10 Stiffening Elements

Masonry walls with inadequate out-of-plane stiffness or strength may be stiffened with external structural members. The stiffening members should be proportioned to resist a tributary portion of lateral load applied normal to the plane of a masonry wall. Connections at the ends of the stiffening element should be provided to transfer the reaction force. Flexibility of the stiffening element should be considered when estimating lateral drift of a masonry wall panel.

Stiffness assumptions, strength criteria, and acceptable deformations for stiffened masonry walls should be the same as that for existing masonry walls. The stiffening action that the new element provides shall be considered.

C7.4.1.3.11 Veneer Attachment

Veneer not bonded to the structural core of a masonry wall may be rehabilitated by the use of pins inserted through the joints and into the brick substrate. Spacing of pins should match current code requirements given the seismicity of the region.

7.4.2 Unreinforced Masonry Walls and Piers In-Plane

Engineering properties of unreinforced masonry (URM) walls subjected to lateral forces applied parallel to their plane shall be determined in accordance with this section. Requirements of this section shall apply to cantilevered shear walls that are fixed against rotation at their base, and piers between window or door openings that are fixed against rotation top and bottom.

Stiffness and strength criteria presented in this section shall apply to both the Linear Static and Nonlinear Static Procedures prescribed in Chapter 3.

7.4.2.1 Stiffness

The lateral stiffness of masonry walls subjected to lateral in-plane forces shall be determined considering both flexural and shear deformations.

The masonry assemblage of units, mortar, and grout shall be considered to be a homogeneous medium for stiffness computations with an expected elastic modulus in compression, E_{me} , as specified in Section 7.3.2.4.

For linear procedures, the stiffness of a URM wall or pier resisting lateral forces parallel to its plane shall be considered to be linear and proportional with the geometrical properties of the uncracked section excluding veneer wythes.

Story shears in perforated shear walls shall be distributed to piers in proportion to the relative lateral uncracked stiffness of each pier.

Stiffnesses for existing and enhanced walls shall be determined using principles of mechanics used for new walls.

C7.4.2.1 Stiffness

Laboratory tests of solid shear walls have shown that behavior can be depicted at low force levels using conventional principles of mechanics for homogeneous materials. In such cases, the lateral in-plane stiffness of a solid cantilevered shear wall, k , can be calculated using Equation (C7-1):

$$k = \frac{1}{\frac{h_{eff}^3}{3E_m I_g} + \frac{h_{eff}}{A_v G_m}} \quad (C7-1)$$

where:

h_{eff} = Wall height

A_v = Shear area

I_g = Moment of inertia for the gross section representing uncracked behavior

E_m = Masonry elastic modulus

G_m = Masonry shear modulus

Correspondingly, the lateral in-plane stiffness of a pier between openings with full restraint against rotation at its top and bottom can be calculated using Equation (C7-2):

$$k = \frac{1}{\frac{h_{eff}^3}{12E_m I_g} + \frac{h_{eff}}{A_v G_m}} \quad (C7-2)$$

The design professional should be aware that a completely fixed condition is often not present in actual buildings.

7.4.2.2 Strength

7.4.2.2.1 Expected Lateral Strength of Unreinforced Masonry Walls and Piers

Expected lateral strength, Q_{CE} , of existing and enhanced URM walls or pier components shall be the lesser of the lateral strength based on expected bed-joint sliding shear strength or expected rocking strength, calculated in accordance with Equations (7-3) and (7-4), respectively:

$$Q_{CE} = V_{bjs} = v_{me} A_n \quad (7-3)$$

$$Q_{CE} = V_r = 0.9\alpha P_E \left(\frac{L}{h_{eff}} \right) \quad (7-4)$$

where:

A_n = Area of net mortared/grouted section

h_{eff} = Height to resultant of lateral force

L = Length of wall or pier

P_E = Expected axial compressive force due to gravity loads specified in Equation (3-3)

v_{me} = Expected bed-joint sliding shear strength in accordance with Section 7.3.2.6

V_{bjs} = Expected shear strength of wall or pier based on bed-joint sliding shear strength

V_r = Strength of wall or pier based on rocking

α = Factor equal to 0.5 for fixed-free cantilever wall, or equal to 1.0 for fixed-fixed pier

7.4.2.2.2 Lower Bound Lateral Strength of Unreinforced Masonry Walls and Piers

Lower bound lateral strength, Q_{CL} , of existing and enhanced URM walls or pier components shall be taken as the lesser of the lateral strength values based on diagonal tension stress or toe compressive stress calculated in accordance with Equations (7-5) and (7-6), respectively. L/h_{eff} shall not be taken less than 0.67 for use in Equation (7-6).

$$Q_{CL} = V_{dt} = f'_{dt} A_n \left(\frac{L}{h_{eff}} \right) \sqrt{1 + \frac{f_a}{f'_{dt}}} \quad (7-5)$$

$$Q_{CL} = V_{tc} = \alpha P_L \left(\frac{L}{h_{eff}} \right) \left(1 - \frac{f_a}{0.7f'_m} \right) \quad (7-6)$$

where A_n , h_{eff} , L , and α are the same as given for Equations (7-3) and (7-4), and:

- f_a = Axial compressive stress due to gravity loads specified in Equation (3-3)
- f'_{dt} = Lower bound masonry diagonal tension strength
- f'_m = Lower bound masonry compressive strength
- P_L = Lower bound axial compressive force due to gravity loads specified in Equation (3-4)
- V_{dt} = Lower bound shear strength based on diagonal tension stress for wall or pier
- V_{tc} = Lower bound shear strength based on toe compressive stress for wall or pier

Substitution of the bed-joint shear strength, v_{me} , for the diagonal tension strength, f'_{dt} , in Equation (7-5) shall be permitted.

The lower bound masonry compressive strength, f'_m , shall be taken as the expected strength, f_{me} , determined in accordance with Section 7.3.2.3, divided by 1.6.

7.4.2.2.3 Lower Bound Vertical Compressive Strength of Unreinforced Masonry Walls and Piers

Lower bound vertical compressive strength of existing URM walls or pier components shall be limited by lower bound masonry compressive stress in accordance with Equation (7-7):

$$Q_{CL} = P_{CL} = 0.80(0.85f'_m A_n) \quad (7-7)$$

where f'_m is equal to the lower bound compressive strength determined in accordance with Section 7.3.2.3.

7.4.2.3 Acceptance Criteria

Unreinforced masonry walls and piers shall be considered deformation-controlled components if their expected lateral strength limited by bed-joint sliding shear stress or rocking, as specified in Section 7.4.2.2.1, is less than the lower bound lateral strength limited by diagonal tension or toe compressive stress, as specified in Section 7.4.2.2.2. Unreinforced masonry walls not meeting the criteria for deformation-controlled components shall be considered force-controlled components. Axial compression on URM wall components shall be considered force-controlled.

7.4.2.3.1 Linear Procedures

For the linear procedures in Sections 3.3.1 and 3.3.2, component actions shall be compared with capacities in accordance with Section 3.4.2.2. The expected strength, Q_{CE} , for use in Equation (3-20) for components classified as deformation-controlled, shall be the lower of the two expected strengths as determined from Equations (7-3) and (7-4). The m -factors for use with corresponding expected strength shall be obtained from Table 7-3.

Table 7-3 Linear Static Procedure— m -factors for URM In-Plane Walls and Piers

Limiting Behavioral Mode	<i>m</i> -factors				
	Performance Level				
	IO	Primary		Secondary	
		LS	CP	LS	CP
Bed-Joint Sliding	1	3	4	6	8
Rocking	$1.5h_{eff}/L$ (not less than 1)	$3h_{eff}/L$ (not less than 1.5)	$4h_{eff}/L$ (not less than 2)	$6h_{eff}/L$ (not less than 3)	$8h_{eff}/L$ (not less than 4)

Interpolation shall be used between table values.

Table 7-4 Nonlinear Static Procedure—Simplified Force-Deflection Relations for URM In-Plane Walls and Piers

Limiting Behavioral Mode	Acceptance Criteria							
	Performance Level							
	c %	d %	e %	IO %	Primary		Secondary	
					LS %	CP %	LS %	CP %
Bed-Joint Sliding	0.6	0.4	0.8	0.1	0.3	0.4	0.6	0.8
Rocking	0.6	$0.4h_{eff}/L$	$0.8h_{eff}/L$	0.1	$0.3h_{eff}/L$	$0.4h_{eff}/L$	$0.6h_{eff}/L$	$0.8h_{eff}/L$

Interpolation shall be used between table values.

For determination of m -factors from Table 7-3, the vertical compressive stress, f_{ae} , shall be based on an expected value of gravity compressive force given by the load combination in Equation (3-3).

7.4.2.3.2 Nonlinear Procedures

For the Nonlinear Static Procedure given in Section 3.3.3, wall and pier components shall meet the requirements of Section 3.4.3.2. For deformation-controlled components, nonlinear deformations shall not exceed the values given in Table 7-4. Variables d and e , representing nonlinear deformation capacities for primary and secondary components, shall be expressed in terms of drift ratio percentages as defined in Figure 7-1. The limiting behavior mode in Table 7-4 shall be identified from the lower of the two expected strengths as determined from Equations (7-3) and (7-4).

For the Nonlinear Dynamic Procedure given in Section 3.3.4, wall and pier components shall meet the requirements of Section 3.4.3.2. Nonlinear force-deflection relations for deformation-controlled wall and pier components shall be established based on the information given in Table 7-4, or an approved procedure based on a comprehensive evaluation of the hysteretic characteristics of those components.

7.4.3 Unreinforced Masonry Walls Out-of-Plane

As required by Section 2.6.7, URM walls shall be evaluated for out-of-plane inertial forces as isolated components spanning between floor levels, and/or spanning horizontally between columns or pilasters. URM walls shall not be analyzed out-of-plane with the Linear or Nonlinear Static Procedures prescribed in Chapter 3.

7.4.3.1 Stiffness

The out-of-plane stiffness of walls shall be neglected in analytical models of the global structural system in the orthogonal direction.

7.4.3.2 Strength

Unless arching action is considered, flexural cracking shall be limited by the expected tensile stress values given in Section 7.3.2.5.

Arching action shall be considered only if surrounding floor, roof, column, or pilaster elements have sufficient stiffness and strength to resist thrusts from arching of a wall panel, and a condition assessment has been performed to ensure that there are no gaps between a wall panel and the adjacent structure.

The condition of the collar joint shall be considered when estimating the effective thickness of a wall for out-of-plane behavior. The effective void ratio shall be taken as the ratio of the collar joint area without mortar to the total area of the collar joint. Wythes separated by collar joints that are not bonded, or have an effective

void ratio greater than 50% shall not be considered part of the effective thickness of the wall.

C7.4.3.2 Strength

This section applies to treatment of veneer for out-of-plane behavior of walls only. For in-plane resistance, effective thickness is the sum of all wythes without consideration of the condition of the collar joints.

7.4.3.3 Acceptance Criteria

For the Immediate Occupancy Structural Performance Level, flexural cracking in URM walls due to out-of-plane inertial loading shall not be permitted as limited by the tensile stress requirements of Section 7.4.3.2. For the Life Safety and Collapse Prevention Structural Performance Levels, flexural cracking in URM walls due to out-of-plane inertial loading shall be permitted provided that cracked wall segments will remain stable during dynamic excitation. Stability shall be checked using analytical time-step integration models considering acceleration time histories at the top and base of a wall panel. For the Life Safety and Collapse Prevention Structural Performance Levels, stability need not be checked for walls spanning vertically with a height-to-thickness (h/t) ratio less than that given in Table 7-5.

C7.4.3.3 Acceptance Criteria

For further information on evaluating the stability of unreinforced masonry walls out-of-plane, refer to *ABK* (1984).

Table 7-5 Permissible h/t Ratios for URM Out-of-Plane Walls

Wall Types	$S_{X1} \leq 0.24g$	$0.24g < S_{X1} \leq 0.37g$	$S_{X1} > 0.37g$
Walls of one-story buildings	20	16	13
First-story wall of multistory building	20	18	15
Walls in top story of multistory building	14	14	9
All other walls	20	16	13

7.4.4 Reinforced Masonry Walls and Piers In-Plane

7.4.4.1 Stiffness

The stiffness of a reinforced masonry wall or pier component in-plane shall be determined as follows:

1. The shear stiffness of RM wall components shall be based on uncracked section properties.
2. The flexural stiffness of RM wall components shall be based on cracked section properties. Use of a cracked moment of inertia equal to 50 percent of I_g shall be permitted.

In either case, veneer wythes shall not be considered in the calculation of wall component properties. Stiffnesses for existing and new walls shall be assumed to be the same.

7.4.4.2 Strength

The strength of RM wall or pier components in flexure, shear, and axial compression shall be determined in accordance with the requirements of this section. The assumptions, procedures, and requirements of this section shall apply to both existing and new RM wall or pier components.

7.4.4.2.1 Flexural Strength of Walls and Piers

Expected flexural strength of an RM wall or pier shall be determined based on the following assumptions:

1. Stress in reinforcement below the expected yield strength, f_{ye} , shall be taken as the expected modulus of elasticity, E_{se} , times the steel strain. For reinforcement strains larger than those corresponding to the expected yield strength, the stress in the reinforcement shall be considered independent of strain and equal to the expected yield strength, f_{ye} .
2. Tensile strength of masonry shall be neglected when calculating the flexural strength of a reinforced masonry cross-section.
3. Flexural compressive stress in masonry shall be assumed to be distributed across an equivalent rectangular stress block. Masonry stress of 0.85 times the expected compressive strength, f_{me} , shall be distributed uniformly over an equivalent

compression zone bounded by the edge of the cross-section and a depth equal to 85% of the depth from the neutral axis to the extreme fiber of the cross-section.

4. Strains in the reinforcement and masonry shall be considered linear through the cross-section. For purposes of determining forces in reinforcing bars distributed across the section, the maximum compressive strain in the masonry shall be assumed to be equal to 0.003.

7.4.4.2.2 Shear Strength of Walls and Piers

The lower-bound shear strength of RM wall or pier components, V_{CL} , shall be determined using Equation (7-8):

$$Q_{CL} = V_{CL} = V_{mL} + V_{sL} \quad (7-8)$$

where:

- V_{mL} = Lower bound shear strength provided by masonry
- V_{sL} = Lower bound shear strength provided by reinforcement

The lower bound shear strength of an RM wall or pier, V_{CL} , shall not exceed the value computed in accordance with Equations (7-9) and (7-10). For intermediate values of M/Vd_v , interpolation shall be used.

For M/Vd_v less than 0.25:

$$V_{CL} \leq 6 \sqrt{f'_m} A_n \quad (7-9)$$

For M/Vd_v greater than or equal to 1.00:

$$V_{CL} \leq 4 \sqrt{f'_m} A_n \quad (7-10)$$

where:

- A_n = Area of net mortared/grouted section
- f'_m = Lower bound compressive strength of masonry
- M = Moment on the masonry section
- V = Shear on the masonry section
- d_v = Wall length in direction of shear force

The lower-bound shear strength, V_{mL} , provided by the masonry shall be determined using Equation (7-11):

$$V_{mL} = \left[4.0 - 1.75 \left(\frac{M}{Vd_v} \right) \right] A_n \sqrt{f'_m} + 0.25 P_L \quad (7-11)$$

where M/Vd_v shall be limited to 1.0, and P_L is the lower-bound vertical compressive force in pounds due to gravity loads, specified in Equation (3-4).

The lower-bound shear strength, V_{sL} , resisted by the reinforcement shall be determined using Equation (7-12):

$$V_{sL} = 0.5 \left(\frac{A_v}{s} \right) f_y d_v \quad (7-12)$$

where:

- A_v = Area of shear reinforcement
- s = Spacing of shear reinforcement
- f_y = Lower bound yield strength of shear reinforcement

For RM walls or piers in which shear is considered a deformation-controlled action, expected shear strength, V_{CE} , shall be calculated using Equations (7-8) through (7-12) substituting expected material properties in lieu of lower-bound.

7.4.4.2.3 Strength Considerations for Flanged Walls

Wall intersections shall be considered effective in transferring shear when either condition (1) or (2) and condition (3) are met:

1. The face shells of hollow masonry units are removed and the intersection is fully grouted.
2. Solid units are laid in running bond, and 50% of the masonry units at the intersection are interlocked.
3. Reinforcement from one intersecting wall continues past the intersection a distance not less than 40 bar diameters or 24 inches.

The width of flange considered effective in compression on each side of the web shall be taken as the lesser of six times the thickness of the web, half the

distance to the next web, or the actual flange on either side of the web wall.

The width of flange considered effective in tension on each side of the web shall be taken as the lesser of 3/4 of the wall height, half the distance to an adjacent web, or the actual flange on either side of the web wall.

7.4.4.2.4 Vertical Compressive Strength of Walls and Piers

Lower bound vertical compressive strength of existing RM wall or pier components shall be determined using Equation (7-13):

$$Q_{CL} = P_{CL} = 0.8[0.85f'_m (A_n - A_s) + A_s f_y] \quad (7-13)$$

where:

f'_m = Lower bound masonry compressive strength determined in accordance with Section 7.3.2.3

f_y = Lower bound reinforcement yield strength determined in accordance with Section 7.3.2.8

7.4.4.3 Acceptance Criteria

The shear required to develop the expected strength of reinforced masonry walls and piers in flexure shall be compared to the lower bound shear strength defined in Section 7.4.4.2.2. For reinforced masonry wall components governed by flexure, flexural actions shall be considered deformation-controlled. For reinforced masonry components governed by shear, shear actions shall be considered deformation-controlled. Axial compression on reinforced masonry wall or pier components shall be considered force-controlled. Expected strength in flexure shall be determined in accordance with Section 7.4.4.2.1, and lower bound strength in axial compression shall be determined in accordance with Section 7.4.4.2.4.

7.4.4.3.1 Linear Procedures

For the linear procedures of Section 3.3.2, component actions shall be compared with capacities in accordance with Section 3.4.2.2. The m -factor for use in Equation (3-20) for those components classified as deformation-controlled shall be as specified in Table 7-6.

For determination of m -factors from Table 7-6, the ratio of vertical compressive stress to expected compressive strength, f_{ae}/f_{me} , shall be based on gravity compressive force determined in accordance with the load combinations given in Equations (3-3) and (3-4).

7.4.4.3.2 Nonlinear Procedures

For the Nonlinear Static Procedure of Section 3.3.3, wall and pier components shall meet the requirements of Section 3.4.3.2. Nonlinear deformations on deformation-controlled components shall not exceed the values given in Table 7-7. Variables d and e , representing nonlinear deformation capacities for primary and secondary components, shall be expressed in terms of story drift ratio percentages as defined in Figure 7-1.

For determination of the c , d , and e values and the acceptable drift levels using Table 7-7, the vertical compressive stress, f_{ae} , shall be based on gravity compressive force determined in accordance with the load combinations given in Equations (3-3) and (3-4).

For the Nonlinear Dynamic Procedure of Section 3.3.4, wall and pier components shall meet the requirements of Section 3.4.3.2. Nonlinear force-deflection relations for deformation-controlled wall and pier components shall be established based on the information given in Table 7-7, or an approved procedure based on comprehensive evaluation of the hysteretic characteristics of those components.

Acceptable deformations for existing and new walls shall be assumed to be the same.

C7.4.4.3.2 Nonlinear Procedures

For primary components, collapse is considered at lateral drift percentages exceeding values of d in Table 7-7, and the Life Safety Structural Performance Level is considered at approximately 75% of d . For secondary components, collapse is considered at lateral drift percentages exceeding the values of e in the table, and the Life Safety Structural Performance Level is considered at approximately 75% of e . Story drift ratio percentages based on these criteria are given in Table 7-7.

Table 7-6 Acceptance Criteria for Linear Procedures—Reinforced Masonry In-Plane Walls

f_{ae}/f_{me}	L/h_{eff}	$\rho_g f_{ye}/f_{me}$	m -factors ¹				
			Performance Level				
			IO	Component Type			
				Primary		Secondary	
LS	CP	LS		CP			
Wall Components Controlled by Flexure							
0.00	≤ 0.5	0.01	4.0	7.0	8.0	8.0	10.0
		0.05	2.5	5.0	6.5	8.0	10.0
		0.20	1.5	2.0	2.5	4.0	5.0
	1.0	0.01	4.0	7.0	8.0	8.0	10.0
		0.05	3.5	6.5	7.5	8.0	10.0
		0.20	1.5	3.0	4.0	6.0	8.0
	≥ 2.0	0.01	4.0	7.0	8.0	8.0	10.0
		0.05	3.5	6.5	7.5	8.0	10.0
		0.20	2.0	3.5	4.5	7.0	9.0
0.038	≤ 0.5	0.01	3.0	6.0	7.5	8.0	10.0
		0.05	2.0	3.5	4.5	7.0	9.0
		0.20	1.5	2.0	2.5	4.0	5.0
	1.0	0.01	4.0	7.0	8.0	8.0	10.0
		0.05	2.5	5.0	6.5	8.0	10.0
		0.20	1.5	2.5	3.5	5.0	7.0
	≥ 2.0	0.01	4.0	7.0	8.0	8.0	10.0
		0.05	3.5	6.5	7.5	8.0	10.0
		0.20	1.5	3.0	4.0	6.0	8.0
0.075	≤ 0.5	0.01	2.0	3.5	4.5	7.0	9.0
		0.05	1.5	3.0	4.0	6.0	8.0
		0.20	1.0	2.0	2.5	4.0	5.0
	1.0	0.01	2.5	5.0	6.5	8.0	10.0
		0.05	2.0	3.5	4.5	7.0	9.0
		0.20	1.5	2.5	3.5	5.0	7.0
	≥ 2.0	0.01	4.0	7.0	8.0	8.0	10.0
		0.05	2.5	5.0	6.5	8.0	10.0
		0.20	1.5	3.0	4.0	4.0	8.0
Wall Components Controlled by Shear							
All cases ²	All cases ²	All cases ²	2.0	2.0	3.0	2.0	3.0

1. Interpolation shall be used between table values.

2. For wall components governed by shear, the axial load on the member must be less than or equal to $0.15 A_g f'_m$, otherwise the component shall be treated as force-controlled.

Table 7-7 Modeling Parameters and Acceptance Criteria for Nonlinear Procedures—Reinforced Masonry In-plane Walls

f_{ae}/f_{me}	L/h_{eff}	$\rho_g f_{ye}/f_{me}$	c	d	e	IO	Acceptable Drift Ratio (%) ¹			
							Performance Level			
							Component Type			
							Primary		Secondary	
							LS	CP	LS	CP
Wall Components Controlled by Flexure										
0.00	≤ 0.5	0.01	0.5	2.6	5.3	1.0	2.0	2.6	3.9	5.3
		0.05	0.6	1.1	2.2	0.4	0.8	1.1	1.6	2.2
		0.20	0.7	0.5	1.0	0.2	0.4	0.5	0.7	1.0
	1.0	0.01	0.5	2.1	4.1	0.8	1.6	2.1	3.1	4.1
		0.05	0.6	0.8	1.6	0.3	0.6	0.8	1.2	1.6
		0.20	0.7	0.3	0.6	0.1	0.2	0.3	0.5	0.6
	≥ 2.0	0.01	0.5	1.6	3.3	0.6	1.2	1.6	2.5	3.3
		0.05	0.6	0.6	1.3	0.2	0.5	0.6	0.9	1.3
		0.20	0.7	0.2	0.4	0.1	0.2	0.2	0.3	0.4
0.038	≤ 0.5	0.01	0.4	1.0	2.0	0.4	0.8	1.0	1.5	2.0
		0.05	0.5	0.7	1.4	0.3	0.5	0.7	1.0	1.4
		0.20	0.6	0.4	0.9	0.2	0.3	0.4	0.7	0.9
	1.0	0.01	0.4	0.8	1.5	0.3	0.6	0.8	1.1	1.5
		0.05	0.5	0.5	1.0	0.2	0.4	0.5	0.7	1.0
		0.20	0.6	0.3	0.6	0.1	0.2	0.3	0.4	0.6
	≥ 2.0	0.01	0.4	0.6	1.2	0.2	0.4	0.6	0.9	1.2
		0.05	0.5	0.4	0.7	0.1	0.3	0.4	0.5	0.7
		0.20	0.6	0.2	0.4	0.1	0.1	0.2	0.3	0.4
0.075	≤ 0.5	0.01	0.3	0.6	1.2	0.2	0.5	0.6	0.9	1.2
		0.05	0.4	0.5	1.0	0.2	0.4	0.5	0.8	1.0
		0.20	0.5	0.4	0.8	0.1	0.3	0.4	0.6	0.8
	1.0	0.01	0.3	0.4	0.9	0.2	0.3	0.4	0.7	0.9
		0.05	0.4	0.4	0.7	0.1	0.3	0.4	0.5	0.7
		0.20	0.5	0.2	0.5	0.1	0.2	0.2	0.4	0.5
	≥ 2.0	0.01	0.3	0.3	0.7	0.1	0.2	0.3	0.5	0.7
		0.05	0.4	0.3	0.5	0.1	0.2	0.3	0.4	0.5
		0.20	0.5	0.2	0.3	0.1	0.1	0.2	0.2	0.3
Wall Components Controlled by Shear										
All cases ²	All cases ²	All cases ²	0.4	0.75	2.0	0.4	0.6	0.75	0.75	1.5

1. Interpolation shall be used between table values.
 2. For wall components governed by shear, the axial load on the member must be less than or equal to $0.15 A_g f'_m$, otherwise the component shall be treated as force-controlled.

7.4.5 Reinforced Masonry Walls Out-of-Plane

Reinforced masonry (RM) walls shall be capable of resisting out-of-plane inertial forces as isolated components spanning between floor levels, and/or spanning horizontally between columns or pilasters. Walls shall not be analyzed out-of-plane with the Linear or Nonlinear Static Procedures prescribed in Chapter 3, but shall be capable of resisting out-of-plane inertial forces as given in Section 2.6.7, or be capable of responding to earthquake motions as determined using the Nonlinear Dynamic Procedure, while satisfying the deflection criteria given in Section 7.4.5.3.

7.4.5.1 Stiffness

RM walls shall be considered local elements spanning out-of-plane between individual story levels.

The out-of-plane stiffness of walls shall be neglected in analytical models of the global structural system.

Stiffness shall be based on the net mortared/grouted area of the uncracked section, provided that net flexural tensile stress does not exceed the expected tensile strength, f_{te} , in accordance with Section 7.3.2.5.

Stiffness shall be based on the cracked section for a wall when the net flexural tensile stress exceeds the expected tensile strength.

Stiffnesses for existing and new reinforced out-of-plane walls shall be assumed to be the same.

7.4.5.2 Strength

Expected flexural strength shall be based on Section 7.4.4.2.1. For walls with an h/t ratio exceeding 20, second-order moment effects due to out-of-plane deflections shall be considered.

The strength of new and existing walls shall be assumed to be the same.

7.4.5.3 Acceptance Criteria

Out-of-plane forces on reinforced masonry walls shall be considered force-controlled actions. Out-of-plane RM walls shall be sufficiently strong in flexure to resist the out-of-plane loads prescribed in Section 2.6.7.

If the Nonlinear Dynamic Procedure is used, the following performance criteria shall be based on the maximum out-of-plane deflection normal to the plane of a wall.

1. For the Immediate Occupancy Structural Performance Level, the out-of-plane story drift ratio shall be equal to or less than 2%.
2. For the Life Safety Structural Performance Level, the out-of-plane story drift ratio shall be equal to or less than 3%.
3. For the Collapse Prevention Structural Performance Level, the out-of-plane story drift ratio shall be equal to or less than 5%.

Acceptable deformations for existing and new walls shall be assumed to be the same.

C7.4.5.3 Deformation Acceptance Criteria

The limit states specified in this section are based on the masonry units having significant cracking for IO, masonry units at a point of being dislodged and falling out of the wall for LS, and masonry units on the verge of collapse for CP.

7.5 Engineering Properties of Masonry Infills

The requirements of this section shall apply to masonry infill panels comprised of any combination of existing panels, panels enhanced for seismic rehabilitation, and new panels added to an existing building for seismic rehabilitation. The procedures for determination of stiffness, strength, and deformation of masonry infills shall be based on this section and used with the analytical methods and acceptance criteria prescribed in Chapter 3, unless noted otherwise.

Masonry infill panels shall be considered as primary elements of a lateral force-resisting system. If the analysis shows that the surrounding frame remains stable following the loss of an infill panel, infill panels shall not be subject to limits set by the Collapse Prevention Structural Performance Level.

C7.5 Engineering Properties of Masonry Infills

The design professional is referred to *FEMA 306*, *FEMA 307*, and *FEMA 308* for additional information regarding the engineering properties of masonry infills.

7.5.1 Types of Masonry Infills

Infills shall include panels built partially or fully within the plane of steel or concrete frames, and bounded by beams and columns.

Infill panel types considered in this standard include unreinforced clay-unit masonry, concrete masonry, and hollow-clay tile masonry. Infills made of stone or glass block are not addressed in this standard.

Infill panels considered isolated from the surrounding frame shall have gaps at top and sides to accommodate maximum expected lateral frame deflections. Isolated panels shall be restrained in the transverse direction to ensure stability under normal forces. Panels in full contact with the frame elements on all four sides are termed “shear infill panels”.

Frame members and connections surrounding infill panels shall be evaluated for frame-infill interaction effects. These effects shall include forces transferred from an infill panel to beams, columns, and connections, and bracing of frame members across a partial length.

7.5.1.1 Existing Masonry Infills

Existing masonry infills considered in this section shall include all structural infills of a building system that are in place prior to seismic rehabilitation. Infill types included in this section consist of unreinforced and ungrouted panels, and composite or noncomposite panels. Existing infill panels subjected to lateral forces applied parallel with their plane shall be considered separately from infills subjected to forces normal to their plane, as described in Sections 7.5.2 and 7.5.3.

Existing masonry infills shall be assumed to behave the same as new masonry infills, provided that the masonry is in good or fair condition as defined in this standard.

7.5.1.2 New Masonry Infills

New masonry infills shall include all new panels added to an existing lateral-force-resisting system for

structural rehabilitation. Infill types shall include unreinforced or reinforced, grouted, ungrouted, or partially grouted, and composite or noncomposite.

7.5.1.3 Enhanced Masonry Infills

Enhanced masonry infill panels shall include existing infills that are rehabilitated by an approved method.

C7.5.1.3 Enhanced Masonry Infills

Masonry infills may be rehabilitated using the methods described in this section. Masonry infills enhanced in accordance with this section should be analyzed using the same procedures and performance criteria used for new infills.

Unless stated otherwise, methods are applicable to unreinforced infills, and are intended to improve performance of masonry infills subjected to both in-plane and out-of-plane lateral forces.

Guidelines from the following sections pertaining to enhancement methods for reinforced masonry walls listed in Section C7.4.1.3, may also apply to unreinforced masonry infill panels: (1) “Infilled Openings,” (2) “Shotcrete,” (3) “Coatings for URM Walls,” (4) “Grout Injections,” (5) “Repointing,” and (6) “Stiffening Elements.” In addition, the following two enhancement methods may apply to masonry infill panels.

C7.5.1.3.1 Boundary Restraints for Infill Panels

Infill panels not in tight contact with perimeter frame members should be restrained for out-of-plane forces. This may be accomplished by installing steel angles or plates on each side of the infills, and welding or bolting the angles or plates to the perimeter frame members.

C7.5.1.3.2 Joints Around Infill Panels

Gaps between an infill panel and the surrounding frame may be filled if integral infill-frame action is assumed for in-plane response.

7.5.2 Masonry Infills In-Plane

The calculation of masonry infill in-plane stiffness and strength based on nonlinear finite element analysis of a composite frame substructure with infill panels that account for the presence of openings and post-yield cracking of masonry shall be permitted. Alternatively, the methods of Sections 7.5.2.1 and 7.5.2.2 shall be used.

C7.5.2 Masonry Infills In-Plane

Finite element programs such as FEM 1 may be useful in analyzing masonry infills with openings.

7.5.2.1 Stiffness

The elastic in-plane stiffness of a solid unreinforced masonry infill panel prior to cracking shall be represented with an equivalent diagonal compression strut of width, a , given by Equation (7-14). The equivalent strut shall have the same thickness and modulus of elasticity as the infill panel it represents.

$$a = 0.175(\lambda_I h_{col})^{-0.4} r_{inf} \quad (7-14)$$

where:

$$\lambda_I = \left[\frac{E_{me} t_{inf} \sin 2\theta}{4E_{fe} I_{col} h_{inf}} \right]^{\frac{1}{4}}$$

and

h_{col} = Column height between centerlines of beams, in.

h_{inf} = Height of infill panel, in.

E_{fe} = Expected modulus of elasticity of frame material, ksi

E_{me} = Expected modulus of elasticity of infill material, ksi

I_{col} = Moment of inertia of column, in⁴.

L_{inf} = Length of infill panel, in.

r_{inf} = Diagonal length of infill panel, in.

t_{inf} = Thickness of infill panel and equivalent strut, in.

θ = Angle whose tangent is the infill height-to-length aspect ratio, radians

λ_I = Coefficient used to determine equivalent width of infill strut

For noncomposite infill panels, only the wythes in full contact with the frame elements shall be considered when computing in-plane stiffness unless positive anchorage capable of transmitting in-plane forces from frame members to all masonry wythes is provided on all sides of the walls.

Stiffness of cracked unreinforced masonry infill panels shall be represented with equivalent struts; the strut properties shall be determined from analyses that consider the nonlinear behavior of the infilled frame system after the masonry is cracked.

The equivalent compression strut analogy shall be used to represent the elastic stiffness of a perforated unreinforced masonry infill panel; the equivalent strut properties shall be determined from stress analyses of infill walls with representative opening patterns.

Stiffnesses for existing and new infills shall be assumed to be the same.

C7.5.2.1 Stiffness

In-plane lateral stiffness of an infilled frame system is not the same as the sum of the frame and infill stiffnesses because of the interaction of the infill with the surrounding frame. Experiments have shown that under lateral forces, the frame tends to separate from the infill near windward lower and leeward upper corners of the infill panels, causing compressive contact stresses to develop between the frame and the infill at the other diagonally opposite corners. Recognizing this behavior, the stiffness contribution of the infill is represented with an equivalent compression strut connecting windward upper and leeward lower corners of the infilled frame. In such an analytical model, if the thickness and modulus of elasticity of the strut are assumed to be the same as those of the infill, the problem is reduced to determining the effective width of the compression strut. Solidly infilled frames may be modeled with a single compression strut in this fashion.

For global building analysis purposes, the compression struts representing infill stiffness of solid infill panels may be placed concentrically across the diagonals of the frame, effectively forming a concentrically braced frame system (Figure C7-2). In this configuration, however, the forces imposed on columns (and beams) of the frame by the infill are not represented. To account for these effects, compression struts may be placed eccentrically within the frames as shown in Figure C7-3. If the analytical models incorporate eccentrically located compression struts, the results should yield infill effects on columns directly.

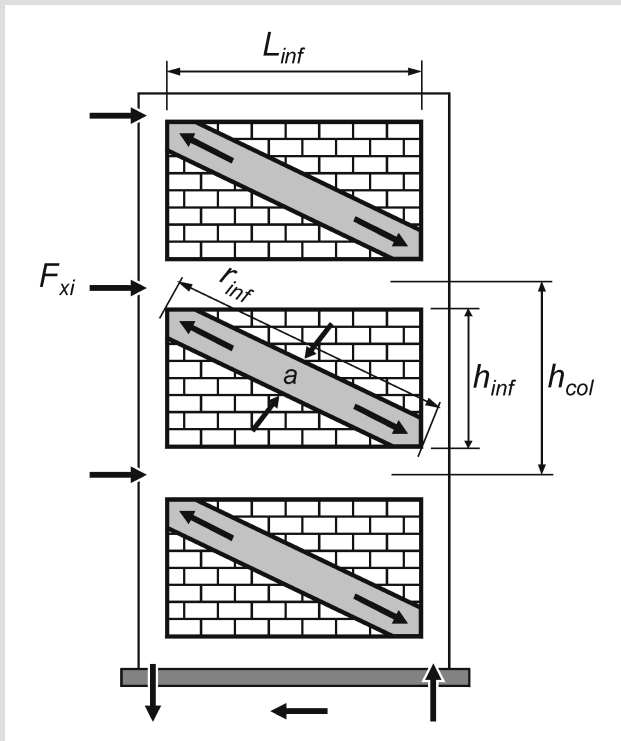

Figure C7-2 Compression Strut Analogy—Concentric Struts

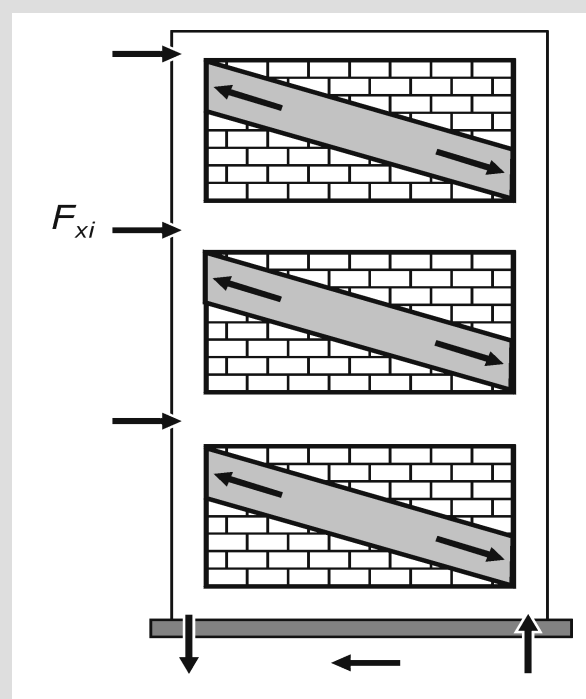

Figure C7-3 Compression Strut Analogy—Eccentric Struts

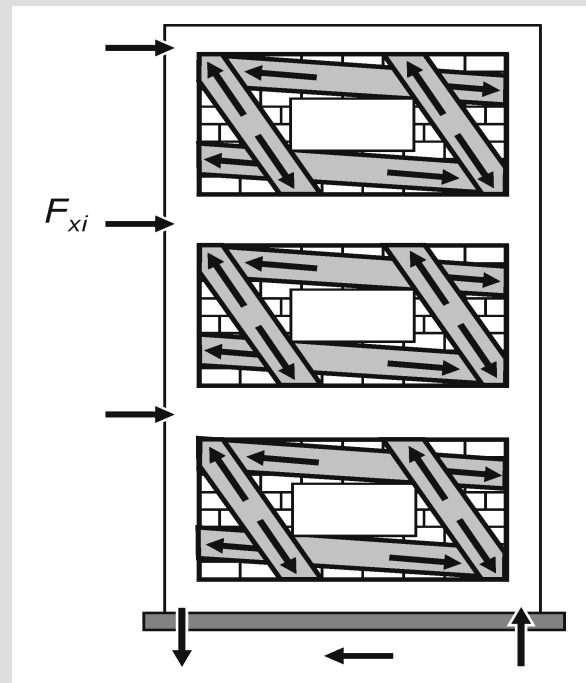

Figure C7-4 Compression Strut Analogy—Perforated Infills

Alternatively, global analyses may be performed using concentric braced frame models, and the infill effects on columns (or beams) may be evaluated at a local level by applying the strut loads onto the columns (or beams).

Diagonally concentric equivalent struts may also be used to incorporate infill panel stiffnesses into analytical models for perforated infill panels (e.g., infills with window openings), provided that the equivalent stiffness of the infill is determined using appropriate analysis methods (e.g., finite element analysis) in a consistent fashion with the global analytical model. Analysis of local effects, however, must consider various possible stress fields that can potentially develop within the infill. A possible representation of these stress fields with multiple compression struts, as shown in Figure C7-4, have been proposed by Hamburger (1993). Theoretical work and experimental data for determining multiple strut placement and strut properties, however, are not sufficient to establish reliable guidelines; the use of this approach requires judgment on a case-by-case basis.

7.5.2.2 Strength

The transfer of story shear across a masonry infill panel confined within a concrete or steel frame shall be considered a deformation-controlled action. Expected in-plane panel shear strength shall be determined in accordance with the requirements of this section.

Expected infill shear strength, V_{ine} , shall be calculated in accordance with Equation (7-15):

$$Q_{CE} = V_{ine} = A_{ni} f_{vie} \quad (7-15)$$

where:

- A_{ni} = Area of net mortared/grouted section across infill panel
- f_{vie} = Expected shear strength of masonry infill

Expected shear strength of existing infills, f_{vie} , shall not exceed the expected masonry bed-joint shear strength, v_{me} , as determined in accordance with Section 7.3.2.6.

Shear strength of new infill panels, f_{vie} , shall not exceed values specified in an approved building code for zero vertical compressive stress.

For noncomposite infill panels, only the wythes in full contact with the frame elements shall be considered when computing in-plane strength, unless positive anchorage capable of transmitting in-plane forces from frame members to all masonry wythes is provided on all sides of the walls.

7.5.2.3 Acceptance Criteria

7.5.2.3.1 Required Strength of Column Members Adjacent to Infill Panels

The expected flexural and shear strengths of column members adjacent to an infill panel shall exceed the forces resulting from one of the following conditions:

1. The application of the horizontal component of the expected infill strut force at a distance l_{ceff} from the top or bottom of the infill panel, where l_{ceff} shall be as defined by Equation (7-16):

$$l_{ceff} = \frac{a}{\cos \theta_c} \quad (7-16)$$

where $\tan \theta_c$ shall be as defined by Equation (7-17):

$$\tan \theta_c = \frac{h_{inf} - \frac{a}{\cos \theta_c}}{L_{inf}} \quad (7-17)$$

2. The shear force resulting from development of expected column flexural strengths at the top and bottom of a column with a reduced height equal to l_{ceff} .

The reduced column length, l_{ceff} , in Equation (7-16) shall be equal to the clear height of opening for a captive column braced laterally with a partial height infill.

The requirements of this section shall be waived if the expected masonry shear strength, v_{me} , as measured in accordance with test procedures of Section 7.3.2.6, is less than 20 psi.

7.5.2.3.2 Required Strength of Beam Members Adjacent to Infill Panels

The expected flexural and shear strengths of beam members adjacent to an infill panel shall exceed forces resulting from one of the following conditions:

1. The application of the vertical component of the expected infill strut force at a distance, l_{beff} from the top or bottom of the infill panel, where l_{beff} shall be as defined by Equation (7-18):

$$l_{beff} = \frac{a}{\sin \theta_b} \quad (7-18)$$

where $\tan \theta_b$ shall be as defined by Equation (7-19):

$$\tan \theta_b = \frac{h_{inf}}{L_{inf} - \frac{a}{\sin \theta_b}} \quad (7-19)$$

2. The shear force resulting from development of expected beam flexural strengths at the ends of a beam member with a reduced length equal to l_{beff}

The requirements of this section shall be waived if the expected masonry shear strength, v_{me} , as measured using the test procedures of Section 7.3.2.6, is less than 50 psi.

7.5.2.3.3 Linear Procedures

Actions on masonry infills shall be considered deformation-controlled. For the linear procedures of Section 3.3.1, component actions shall be compared with capacities in accordance with Section 3.4.2.2. m -factors for use in Equation (3-20) shall be as specified in Table 7-8. For an infill panel, Q_E shall be the horizontal component of the unreduced axial force in the equivalent strut member.

For determination of m -factors in accordance with Table 7-8, the ratio of frame to infill strengths, β , shall be determined considering the expected lateral strength of each component.

7.5.2.3.4 Nonlinear Procedures

For the Nonlinear Static Procedure given in Section 3.3.3, infill panels shall meet the requirements of Section 3.4.3.2. Nonlinear lateral drifts shall not exceed the values given in Table 7-9. The variable d , representing nonlinear deformation capacities, shall be expressed in terms of story drift ratio in percent as defined in Figure 7-1.

Table 7-8 Linear Static Procedure— m -factors for Masonry Infill Panels

$\beta = \frac{V_{fre}}{V_{ine}}$	$\frac{L_{inf}}{h_{inf}}$	m -factors		
		IO	LS	CP
$\beta < 0.7$	0.5	1.0	4.0	n.a.
	1.0	1.0	3.5	n.a.
	2.0	1.0	3.0	n.a.
$0.7 \leq \beta < 1.3$	0.5	1.5	6.0	n.a.
	1.0	1.2	5.2	n.a.
	2.0	1.0	4.5	n.a.
$\beta \geq 1.3$	0.5	1.5	8.0	n.a.
	1.0	1.2	7.0	n.a.
	2.0	1.0	6.0	n.a.

Interpolation shall be used between table values.

For determination of acceptable drift levels using Table 7-9, the ratio of frame to infill strengths, β , shall be determined considering the expected lateral strength of each component.

If the surrounding frame can remain stable following the loss of an infill panel, infill panels shall not be subject to limits set by the Collapse Prevention Structural Performance Level.

For the Nonlinear Dynamic Procedure given in Section 3.3.4, infill panels shall meet the requirements of Section 3.4.3.2. Nonlinear force-deflection relations for infill panels shall be established based on the information given in Table 7-9 or an approved procedure based on a comprehensive evaluation of the hysteretic characteristics of those components.

Acceptable deformations for existing and new infills shall be assumed to be the same.

C7.5.2.3.4 Nonlinear Procedures

The Immediate Occupancy Structural Performance Level is assumed to be reached when significant visual cracking of an unreinforced masonry infill occurs. The Life Safety Structural Performance Level is assumed to be reached when substantial cracking of the masonry infill occurs and the potential is high for the panel, or some portion of it, to drop out of the frame.

Table 7-9 Nonlinear Static Procedure—Simplified Force-Deflection Relations for Masonry Infill Panels

$\beta = \frac{V_{fre}}{V_{ine}}$	$\frac{L_{inf}}{h_{inf}}$	c	d %	e %	Acceptance Criteria	
					LS %	CP %
$\beta < 0.7$	0.5	n.a.	0.5	n.a.	0.4	n.a.
	1.0	n.a.	0.4	n.a.	0.3	n.a.
	2.0	n.a.	0.3	n.a.	0.2	n.a.
$0.7 \leq \beta < 1.3$	0.5	n.a.	1.0	n.a.	0.8	n.a.
	1.0	n.a.	0.8	n.a.	0.6	n.a.
	2.0	n.a.	0.6	n.a.	0.4	n.a.
$\beta \geq 1.3$	0.5	n.a.	1.5	n.a.	1.1	n.a.
	1.0	n.a.	1.2	n.a.	0.9	n.a.
	2.0	n.a.	0.9	n.a.	0.7	n.a.

Note: Interpolation shall be used between table values.

7.5.3 Masonry Infills Out-of-Plane

Unreinforced infill panels with h_{inf}/t_{inf} ratios less than those given in Table 7-10, and meeting the requirements for arching action given in the following section, need not be analyzed for out-of-plane seismic forces.

Flexural stiffness for uncracked masonry infills subjected to transverse forces shall be based on the minimum net sections of mortared and grouted masonry. Flexural stiffness for unreinforced, cracked infills subjected to transverse forces shall be assumed to be equal to zero unless arching action is considered.

Table 7-10 Maximum h_{inf}/t_{inf} Ratios¹

	Low Seismic Zone	Moderate Seismic Zone	High Seismic Zone
IO	14	13	8
LS	15	14	9
CP	16	15	10

1. Out-of-plane analysis shall not be required for infills with h_{inf}/t_{inf} ratios less than the values listed herein.

Arching action shall be considered only if all of the following conditions exist.

1. The panel is in full contact with the surrounding frame components.
2. The product of the elastic modulus, E_{fe} , times the moment of inertia, I_f , of the most flexible frame component exceeds a value of 3.6×10^9 lb-in.²
3. The frame components have sufficient strength to resist thrusts from arching of an infill panel.
4. The h_{inf}/t_{inf} ratio is less than or equal to 25.

7.5.3.1 Stiffness

Infill panels shall be considered local elements spanning out-of-plane vertically between floor levels or horizontally across bays of frames.

The out-of-plane stiffness of infill panels shall be neglected in analytical models of the global structural system in the orthogonal direction.

If arching action is considered, mid-height deflection normal to the plane of an infill panel, Δ_{inf} , divided by the infill height, h_{inf} shall be determined in accordance with Equation (7-20):

$$\frac{\Delta_{inf}}{h_{inf}} = \frac{0.002 \left(\frac{h_{inf}}{t_{inf}} \right)}{1 + \sqrt{1 - 0.002 \left(\frac{h_{inf}}{t_{inf}} \right)^2}} \quad (7-20)$$

For infill panels not meeting the requirements for arching action, deflections shall be determined in accordance with the procedures given in Sections 7.4.3 or 7.4.5.

Stiffnesses for existing and new infills shall be assumed to be the same.

7.5.3.2 Strength

When arching action is not considered, the lower bound strength of a URM infill panels shall be limited by the lower bound masonry flexural tension strength, f'_t , which shall be taken as 0.7 times the expected tensile strength, f_{te} , as determined in accordance with Section 7.3.2.5.

If arching action is considered, the lower bound out-of-plane strength of an infill panel in pounds per square foot, q_{inv} shall be determined using Equation (7-21):

$$Q_{CL} = q_{in} = \frac{0.7f'_m \lambda_2}{\left(\frac{h_{inf}}{t_{inf}} \right)} \times 144 \quad (7-21)$$

where:

f'_m = Lower bound of masonry compressive strength determined in accordance with Section 7.3.2.3

λ_2 = Slenderness parameter as defined in Table 7-11

Table 7-11 Values of λ_2 for Use in Equation (7-21)

h_{inf}/t_{inf}	5	10	15	25
λ_2	0.129	0.060	0.034	0.013

Interpolation shall be used.

7.5.3.3 Acceptance Criteria

Infill panels loaded out-of-plane shall not be analyzed with the Linear or Nonlinear Static Procedures prescribed in Chapter 3.

The lower bound transverse strength of URM infill panels shall exceed normal pressures as prescribed in Section 2.6.7.

If the Nonlinear Dynamic Procedure is used, the following performance criteria shall be based on the maximum out-of-plane deflection normal to the plane of the wall.

1. For the Immediate Occupancy Structural Performance Level, the out-of-plane story drift ratio of a panel shall be equal to or less than 2%.
2. For the Life Safety Structural Performance Level, the out-of-plane story drift ratio of a panel shall be equal to or less than 3%.
3. For the Collapse Prevention Structural Performance Level, the out-of-plane story drift ratio of a panel shall be equal to or less than 5%.

If the surrounding frame is shown to remain stable following the loss of an infill panel, infill panels shall not be subject to limits for the Collapse Prevention Structural Performance Level.

Acceptable deformations of existing and new walls shall be assumed to be the same.

C7.5.3.3 Acceptance Criteria

The Immediate Occupancy Structural Performance level is assumed to be reached when significant visual cracking of an unreinforced masonry infill occurs. The Life Safety Structural Performance Level is assumed to be reached when substantial damage of the unreinforced masonry infill occurs and the potential is high for the panel, or some portion of it, to drop out of the frame.

7.6 Anchorage to Masonry Walls

7.6.1 Types of Anchors

Anchors considered in Section 7.6.2 shall include plate anchors, headed anchor bolts, and bent bar anchor bolts

embedded into clay-unit and concrete masonry. Anchors in hollow-unit masonry shall be embedded in grout.

Pullout and shear strength of expansion anchors shall be verified by approved test procedures.

7.6.2 Analysis of Anchors

Anchors embedded into existing or new masonry walls shall be considered force-controlled components. Lower bound values for strengths of embedded anchors with respect to pullout, shear, and combinations of pullout and shear, shall be as specified in an approved building code.

The minimum effective embedment length for considerations of pullout strength of embedded anchors shall be as specified in the building code. When the embedment length is less than four bolt diameters or two inches, the pullout strength shall be taken as zero.

The minimum edge distance for considerations of full shear strength shall be 12 diameters. Shear strength of anchors with edge distances equal to or less than one inch shall be taken as zero. Linear interpolation of shear strength for edge distances between these two bounds shall be permitted.

C7.6.2 Analysis of Anchors

Anchors in masonry may be analyzed in accordance with *FEMA 302*.

7.7 Masonry Foundation Elements

7.7.1 Types of Masonry Foundations

Masonry foundations shall be rehabilitated in accordance with this section.

C7.7.1 Types of Masonry Foundations

Masonry foundations are common in older buildings and are still used for some modern construction. Such foundations may include footings and foundation walls constructed of stone, clay brick, or concrete block. Generally, masonry footings are unreinforced; foundation walls may or may not be reinforced.

Spread footings transmit vertical column and wall loads to the soil by direct bearing. Lateral forces are transferred through friction between the soil and the masonry, as well as by passive pressure of the soil acting on the vertical face of the footing.

7.7.2 Analysis of Existing Foundations

The deformability of the masonry footings and the flexibility of the soil under them shall be considered in the lateral force analysis of the building system. The strength and stiffness of the soil shall be determined in accordance with the requirements of Section 4.4.

Masonry footings shall be considered force-controlled components. Masonry footings shall be modeled as elastic components with no inelastic deformation capacity, unless verification tests are done in accordance with Section 2.8 to prove otherwise.

Masonry retaining walls shall be evaluated to resist active and passive soil pressures in accordance with Section 4.5. Stiffness, strength, and acceptability criteria for masonry retaining walls shall be the same as that for other masonry walls subjected to out-of-plane loadings, as specified in Sections 7.4.3 and 7.4.5.

7.7.3 Rehabilitation Measures

Masonry foundation elements shall be rehabilitated in accordance with Section 6.13.4 or by another approved method.

C7.7.3 Rehabilitation Measures

Possible rehabilitation methods include:

1. Injection grouting of stone foundations.
2. Reinforcing of URM foundations.
3. Prestressing of masonry foundations.
4. Enlargement of footings by placement of reinforced shotcrete.
5. Enlargement of footings with additional reinforced concrete sections.

Procedures for rehabilitation should follow provisions for enhancement of masonry walls where applicable, according to Section 7.4.1.3.

